



BOURDEAU
PROFFESIONAL KITCHEN

PROFFESIONAL KITCHEN

Micro Wave / Dishwasher / Ranges/ Cook Tops / Refrigerators/ Range Hoods / Hand Made Sinks / Faucets



BOURDEAU-GRIFFIN INTERIORS AND ARCHITECTURAL SUPPLIES, INC

2233 S. Throop St.#209

Chicago, IL 60608

M 312 451 1918

O 312 273 4932

Info@BourdeauGriffin.com

www.BourdeauGriffin.com



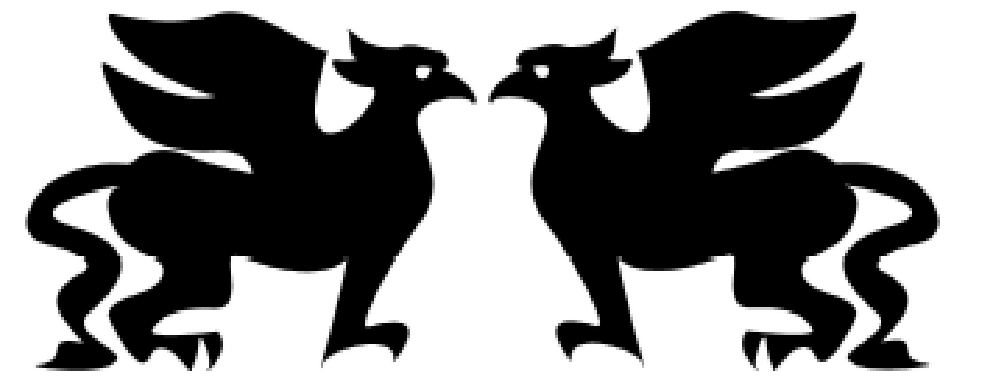

BOURDEAU

GRIFFIN INTERIORS AND ARCHITECTURAL SUPPLIES, INC.

INTERIOR DESIGNERS

LICENSED GENERAL CONTRACTORS

ARCHITECTURAL PRODUCT SUPPLIERS

MBE/WBE AND DBE CERTIFIED



PROFFESIONAL KITCHEN



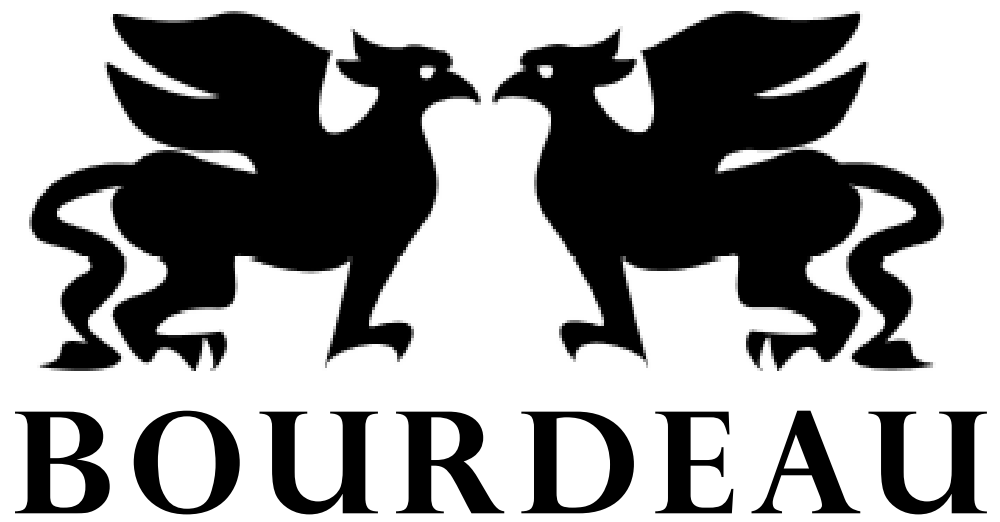

GRIFFIN INTERIORS AND ARCHITECTURAL SUPPLIES, INC.

INTERIOR DESIGNERS

LICENSED GENERAL CONTRACTORS

ARCHITECTURAL PRODUCT SUPPLIERS

MBE/WBE AND DBE CERTIFIED

CSA Certified

- Every gas unit is CSA Certificated.
- We ensure that every product is manufactured with safety and quality.
- Our products being up to the highest standards is our top priority.

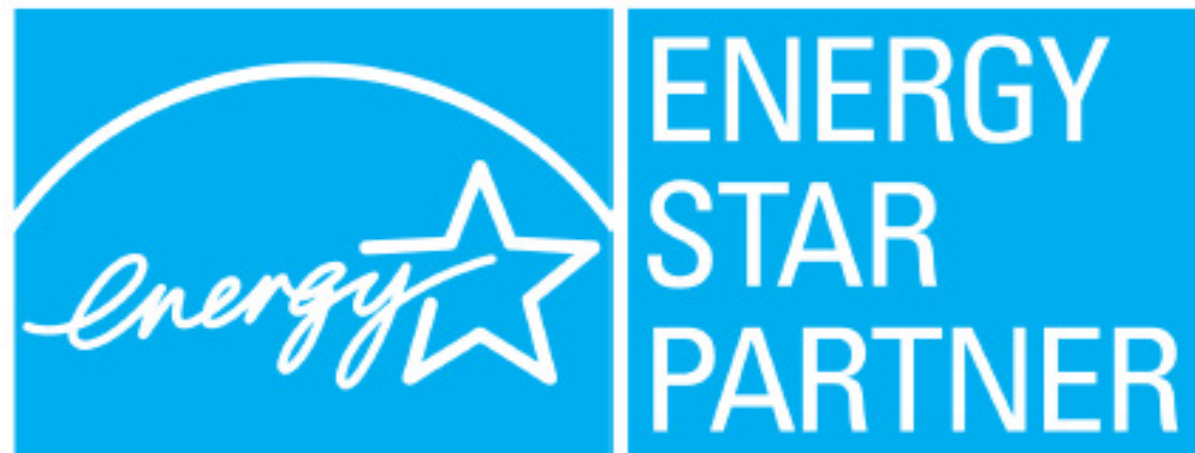

What is ENERGY STAR®?

ENERGY STAR qualified products and practices help you save money and reduce greenhouse gas emissions by meeting strict energy efficiency guidelines set by the U.S. Environmental Protection Agency and the U.S. Department of Energy.



FINE ART & INTERIOR DESIGN



FRANTZIE BOURDEAU GRIFFIN
INTERIOR DESIGNER
COMMERCIAL • RESIDENTIAL
HOTEL • RESTAURANT • OFFICE
KITCHEN • BATH • DRAPERY • BLINDS
FLOORING • FURNITURE • ACCESSORIES





GAS RANGES



BGRG3026U 30" PROFESSIONAL STAINLESS STEEL GAS RANGE

Cook top:
 Front: 2 x Sealed Single Burner x 18,000 BTU
 Back: 2 x Sealed Dual Burner x 15,000 BTU with 650 BTU simmer function Automatic re-ignition if the burner flame extinguishes
 Black Porcelain Drip Pan to facilitate surface cleaning.
 3 x Continuous cast-iron cooking grates
 Oven:
 4.2 cu.ft oven capacity
 Infrared Broil Burner: High-end broiler radiates the heat to sear your food and seal in the juices: 1 x 16,500 BTU; U shape stove burner: 1 x 22,000 BTU
 Blue porcelain oven interior
 Commercial Convection Fan circulates heat for even distribution
 Two Halogen Lights increase visibility for the oven interior
 Thermostatically Controlled to attain the right temperature
 Fuel :LPG/NG: LP conversion kit required for LPG
 Electrical Requirements: 120V/60Hz/15 or 20A

Product Dimension: 26.4" D x 30" W x 38.3" H
 Package Dimension: 33" D x 35" W x 44.5" H
 Product Weight: 250 lbs.



BGRG3617U 36" PROFESSIONAL STAINLESS STEEL GAS RANGE

Cooktop
 Burners: 6
 Sealed Burners: Yes
 Dual Burner: Yes
 Griddle: Yes
 Continuous Grates: Yes
 Porcelain Drip Pan: Yes
 Ovens
 Left Oven Capacity: 2.5 cu. ft.
 Right Oven Capacity: 4.2 cu. ft.
 Total Capacity: 6.7 cu. ft.
 Convection: Yes
 Infrared Broil Burner: Yes
 Halogen Lights: Yes
 Blue Porcelain Interior: Yes
 Accessories
 LP Conversion: Optional
 Warranty
 Parts and Labor: 2 Years
 Electrical Specifications
 Amps: 20A
 Volts: 120V
 Dimensions
 Width: 48" / Depth: 26" / Height: 38"
 Product Weight: 250 lbs.



BGRG4808U 48" 6 BURNER STAINLESS STEEL PROFESSIONAL GAS RANGE

Cook top:
 Front: 3 x Sealed Single Burners x 18,000 BTU
 Back: 3 x Sealed Dual Burners x 15,000 BTU with 650 BTU simmer function Automatic re-ignition if the burner flame extinguishes
 Stainless Steel drip pan
 15,000 BTU Stainless Steel Griddle
 3 x Continuous cast iron cooking grates
 2 x Oven:
 30" unit
 4.2 cu.ft oven capacity
 Infrared Broil Burner: High-end broiler radiates heat to sear your food and seal in the juices: 16,500 BTU
 U-shape bake burner at 22,000 BTU
 Blue oven interior
 Commercial Convection Fan circulates heat for even distribution
 Two Halogen Lights increase visibility for the oven interior
 18" unit:
 2.5 cu.ft oven capacity
 1 tube burner with 14,000 BTU
 One Halogen Light increases visibility for the oven interior Thermostatically Controlled to attain the right temperature Fuel :LPG/NG: LP Conversion Kit required for LPGProduct Weight: 250 lbs.



GPK3618U 36 INCH 6 BURNER RANGE TOP

6 Burners
 2 Dual burners (15,000 BTU with 650 BTU simmer)
 1 Single burner (18,000 BTU)
 3 Single burners (12,000 BTU)
 Continuous Grates
 Effortlessly move heavy cookware across the cooktop. Stainless Steel Controls
 The stainless steel controls combine style and functionality. Porcelain Drip Pan
 Easily clean up any spills.
 Electrical Specifications
 Amps: 15A
 Volts: 120V
 Dimensions
 Width: 36" / Depth: 27" / Height: 7" Cutout Dimensions
 Width: 36"
 Depth: 24"Electrical Specifications
 Amps: 20A
 Volts: 120V
 Dimensions
 Width: 48" / Depth: 26" / Height: 38"





BGPK3003U GAS RANGE TOP

4 Sealed Burners
 2 Sealed 18,000 BTU burners
 2 Sealed 12,000 BTU burners
 Continuous Grates
 Effortlessly move heavy cookware across the cooktop. Stainless Steel Controls
 The stainless steel controls combine style and functionality. Porcelain Drip Pan
 Easily clean up any spills.
 Electrical Specifications
 Amps: 15A
 Volts: 120V
 Dimensions
 Width: 30" / Depth: 27 1/10" / Height: 8 1/2" Cutout Dimensions
 Width: 30"
 Depth: 24"



BGRH3605U 48 Inch Under-Cabinet Canopy Hood

Technical Details
 Stainless Steel Baffles: Yes
 Dishwasher Safe Baffles: Yes
 LED Lighting: Yes
 CFM: 1200 CFM
 Speeds: 3
 Electrical Specifications
 Amps: 15A
 Volts: 120V
 Dimensions
 Width: 48" / Depth: 23 1/2" / Height: 18"



BGPK3003U GAS RANGE TOP

4 Sealed Burners
 2 Sealed 18,000 BTU burners
 2 Sealed 12,000 BTU burners
 Continuous Grates
 Effortlessly move heavy cookware across the cooktop. Stainless Steel Controls
 The stainless steel controls combine style and functionality. Porcelain Drip Pan
 Easily clean up any spills.
 Electrical Specifications
 Amps: 15A
 Volts: 120V
 Dimensions
 Width: 30" / Depth: 27 1/10" / Height: 8 1/2" Cutout Dimensions
 Width: 30"
 Depth: 24"



BG3601U 36" PROFESSIONAL STAINLESS STEEL Refrigerator

Refrigerator Capacity	Freezer Capacity	15 cu. ft.
Dimensions		5.3 cu. ft.
Door Clearance		36"W x 27.8"D x 69.9"H 19 3/8"
Packing Dimension	Loading capacity	38.9x31.5x74.4(inch)
(40HQ)		30 with handle assembled
Refrigerant		36 without handle assembled
Energy class		R600a
Certifications		2018 E-star CSANo frost Grip handle
Refrigeration model		Computer
Handle		Stainless steel
Control type		\$78 (654kWh)
Finishing		3-prong grounding-type
Annual Energy Usage		
Receptacle		

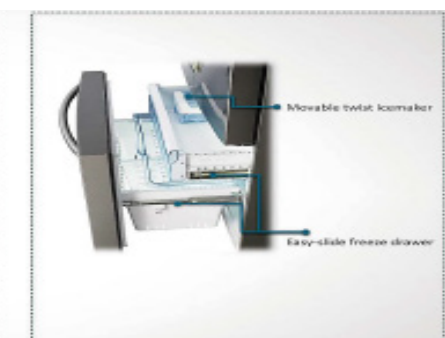
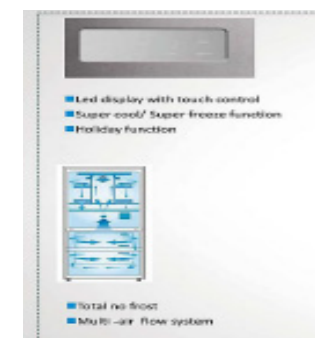



36 inch Commercial Range:BGCR3601U

Stainless Steel front,side and removable shelf

Cooktop:

- 1.6 Heavy Duty Burner x 25,000 BTU
- 2.6 x Heav Duty Flat Cast-iron Cooking Grate

Control panel:

- 1.SS Control panel
- 2:6 x high quality burner control knob, 1 x oven control knob

Oven:

1. 5.58 cu.ft oven capacity
2. U-shape burner: 1 x 30,000 BTU
3. Black porcelain oven interior
4. Quadrant Spring door
5. 2-position rack guides with one removable rack

Fuel :NG/LPG

Product Dimension: 36.5"L*33.75"D*37"H Package Dimension: 1055 L*1055 L*1035 L(mm)



BGWC2403U inch Wine Cooler

- Net Capacity - Litre 428L
- Capacity Bottle --155 Bottles
- Refrigerant R134a or R600a
- Input power 160W
- Dual zone ,Temperature range 5~18°C
- Built-in & free-standing installation
- Wooden shelves
- White LED Interior Light with switch
- Tempered & smoked double pane glass door
- Stainless steel door frame and handle (not seamless)
- Touch pad digital control with blue LED readout, Celsius & Fahrenheit display
- Adjustable thermostat
- No frost with interior fan circulating
- Energy efficient design
- 100% HFC free & FCKW free
- Security lock system (optional)
- CE, ETL,CB,ROHS
- Rated Voltage/Frequency 220V-240V/50Hz or 115V/60Hz

N.W. /G.W. : 86KGS/105KGS

Product Dimension: 595x680x1805MM Package Dimension: 810x890x1950MM



BGWC2401U 24 inch Wine Cooler

- Net capacity--Litre 145L
- Capacity Bottle 46 Bottles
- Refrigerant R134a or R600a
- Input power:100W
- Dual zone ,Temperature range 5~18°C
- Built-in & free-standing installation
- Wooden shelves
- White LED Interior Light with switch
- Tempered & smoked double pane glass door
- Seamless stainless steel door frame and handle
- Touch pad digital control with blue LED readout, Celsius & Fahrenheit display
- Adjustable thermostat
- No frost with interior fan circulating
- Energy efficient design
- 100% HFC free & FCKW free
- Security lock system (optional)
- CE, ETL,CB,ROHS

Rated Voltage/Frequency 220V-240V/50Hz or 115V/60Hz

N.W. /G.W. : 47KGS/65KGS

Product Dimension: 595x570x870MM Package Dimension: 750x735x970MM



BGWC2402U 24 inch Wine Cooler

- Net capacity--Litre 170L
- Capacity Bottle --66 Bottles
- Refrigerant R134a or R600a
- Input power 130W
- Dual zone ,Temperature range 5~18°C
- Built-in & free-standing installation
- Chromed metal shelves
- White LED Interior Light with switch
- Tempered & smoked double pane glass door
- Seamless stainless steel door frame and handle
- Touch pad digital control with blue LED readout, Celsius & Fahrenheit display
- Adjustable thermostat
- No frost with interior fan circulating
- Energy efficient design
- 100% HFC free & FCKW free
- Security lock system (optional)
- CE, ETL,CB,ROHS

Rated Voltage/Frequency 220V-240V/50Hz or 115V/60Hz

N.W. /G.W. : 47KGS/65KGS

Product Dimension: 595x570x870MM Package Dimension: 750x735x970MM

BASIN AND FAUCET SERIES



S1216

Material: Stainless Steel Feature: Without Faucet
Surface Treatment: Brushed Installation Type: Apron Front Bowl Shape:
Rectangular Number of Holes: Two
Sink Style: Double Bowl
Item Name: Apron Sink Thickness: P1.0-2.0mm
Bowl size: Size: 34X18X10" OVERALL SIZE: 838 x558 x254mm



S1215

Material: Stainless Steel Feature: Without Faucet
Surface Treatment: Brushed Installation Type: Apron Front Bowl Shape:
Rectangular Number of Holes: One
Sink Style: Single Bowl
Item Name: Apron Sink Thickness: P1.0-2.0mm
Bowl size: Size: 34X18X10" OVERALL SIZE: 838 x558 x254mm



S1210

Material: Stainless Steel
Feature: Without Faucet
Surface Treatment: Polished
Installation Type: Undermount
Bowl Shape: Square
Number of Holes: One
Sink Style: Single Bowl
Item Name: stainless steel kitchen sink
Color: Silver
Corner: Zero , R10 , R15 is available
Thickness: 1.0mm , 1.2mm , 1.5mm is available Accessories: Optional
Choice
Certificate: CE , TUV Assessment , CUPC
Sound Deadening Pads: Bottom
Popular area: Asia, North America, South America, Europe
Usage: For Hotel, Restaurant, Home, School, Bar, Hospital, Laboratory
Size: 31 X 18 X 9"



S1214

Material: Stainless Steel
Feature: With Faucet
Surface Treatment: Polished
Installation Type: Undermount
Bowl Shape: Square
Number of Holes: Four
Sink Style: Double Bowl
Item: import sink
Color: Silver
Length: 33in
Width: 18in
Depth: 10in



S2109U

Material: Stainless Steel
Feature: Without Faucet
Surface Treatment: Brushed
Installation Type: Above Counter
Bowl Shape: Rectangular
Number of Holes: Two
Sink Style: Double Bowl
Apron kitchen sink: Double bowl
Certification: CE, TUV Assessment, CUPC
Management System: ISO9001:2008
Desc: Used commercial apron kitchen sink Blanco stainless steel sink
Color: Silver
Thickness: 16g, 18g
Packing: Individual Packing
Size: 31x18x9inch
Finish: Brushed Satin
Corner: R0/R10/R15



S1118

Material: Stainless Steel
Feature: Without Faucet, Anti-rust, anti-corrosive, moisture proof
Surface Treatment: Brushed
Installation Type: Above Counter
Bowl Shape: Rectangular
Number of Holes: One
Sink Style: Single Bowl
Item Name: Handmade Sink Including Dish Drying Rack and Dish Grid
Radiation: R0, R10, R15
Certification: CE, TUV Assessment, CUPC Management System:
ISO9001:2008
Optional accessories: Strainer , steel clown pipe, chopping board,
basket
OEM/ODM: Yes

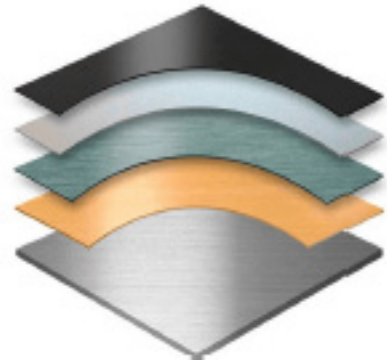

- ① Nano anti-bacterial layer
- ② High temperature anti-corrosion layer
- ③ Acid and alkali anti-rust layer
- ④ High temperature oil-free layer
- ⑤ 304 stainless steel

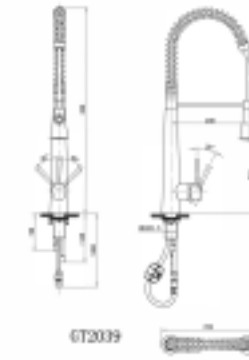

GT2039

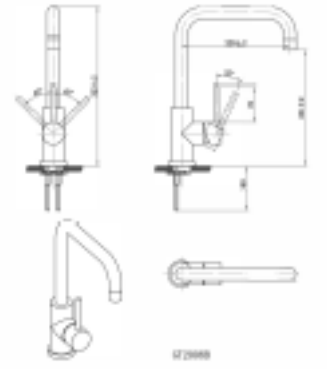

GT2008B

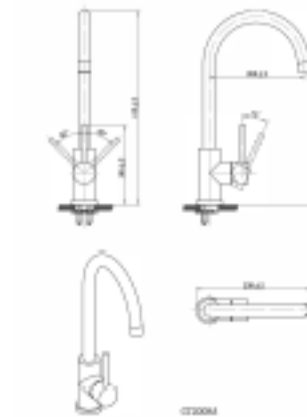

GT2008A

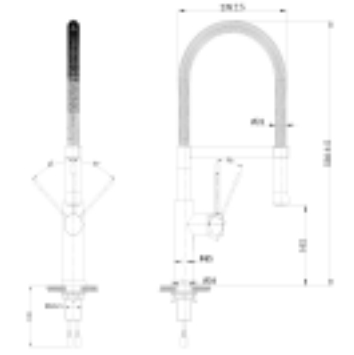

GT2015

GT2015

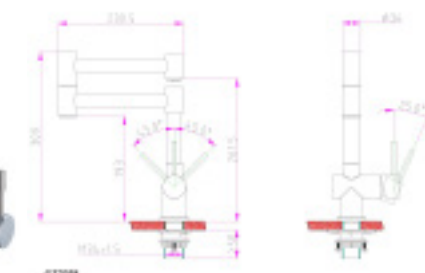

GT2038

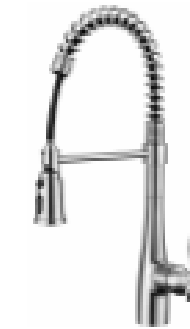



Versatile installation

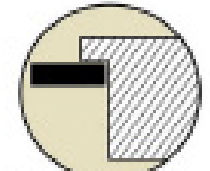

Drop-in mount

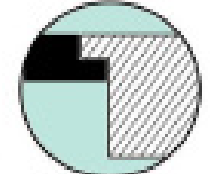

Flush mount

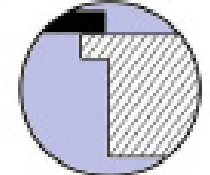

Under mount





BOURDEAU

PROFFESIONAL KITCHEN

Micro Wave / Dishwasher / Ranges/ Cook Tops / Refrigerators/ Range Hoods / Hand Made Sinks / Faucets



BOURDEAU-GRIFFIN INTERIORS AND ARCHITECTURAL SUPPLIES, INC

2233 S. Throop St.#209

Chicago, IL 60608

M 312 451 1918

O 312 273 4932

Info@BourdeauGriffin.com

www.BourdeauGriffin.com

