

BOURDIEAU

**RANGE HOODS**

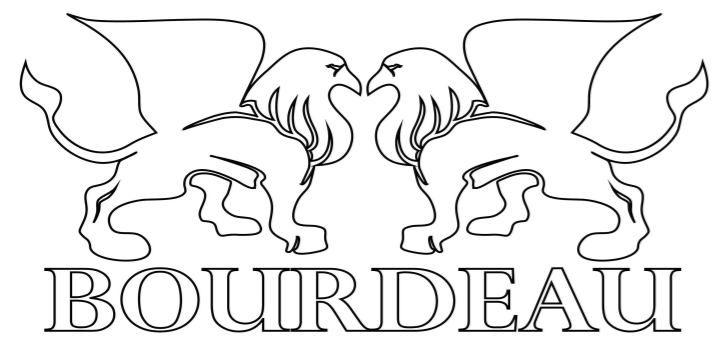

*Product Introdct on*



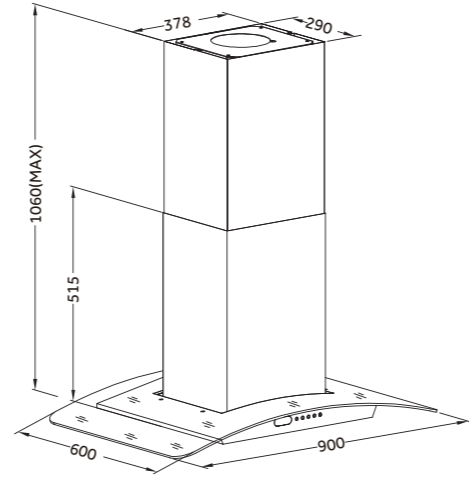

**VIS90A-G2L160**

Technical specification	Technical information	Optional:
General Input: 164W	Extraction or recirculation	4 x 20W halogen lights
Airflow: 750m³/h	Push button control	
Noise Level: ≤58dB	160W motor	
Net Weight: 22.5kgs	4 x 1W LED lights	
Gross Weight: 26.5kgs	90cm width	
Appliance Dimension : 900×600×340mm	Cassette metallic filter	
Packing Dimension: 1000×500×667mm	Island installation	
Container Loading(20' /40' /40' HQ pcs): 66/138/172		

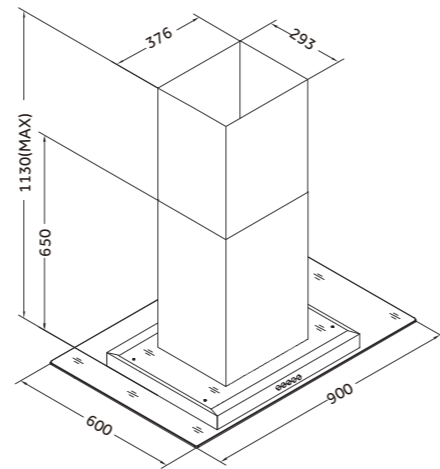

**VIS90A-G4L160**

Technical specification	Technical information	Optional:
General input: 162W	Push button control	Halogen lights
Airflow: 750m³/h	3 speeds	
Noise level: ≤58dB	160W motor	
Net weight: 22.5kgs	2 x 1W LED lights	
Gross weight: 25.8kgs	90cm width	
Appliance dimension : 900×600×(650~1130)mm	Cassette metallic filter	
Packing dimension: 975×400×675mm		
Container loading(20' /40' /40' HQ pcs): 90/200/240		

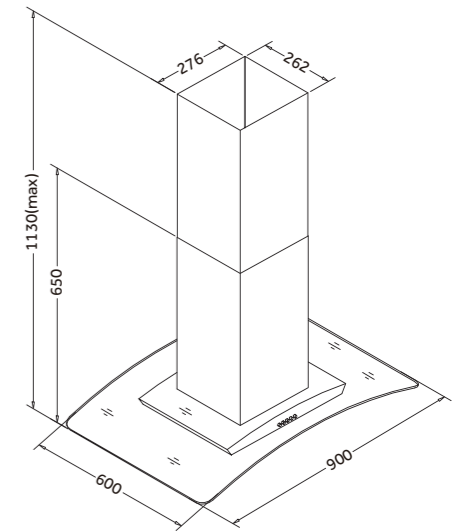

**VIS90A-G3**

Technical specification	Technical information	Optional:
General input: 162W	Push button control	Halogen lights
Airflow: 750m³/h	3 speeds	Energy glass A
Noise level: ≤58dB	160W motor	
Net weight: 22.5kgs	2 x 1W LED lights	
Gross weight: 25.8kgs	90cm width	
Appliance dimension : 900×600×(650~1130)mm	Cassette metallic filter	
Packing dimension: 975×400×675mm		
Container loading(20' /40' /40' HQ pcs): 90/200/240		

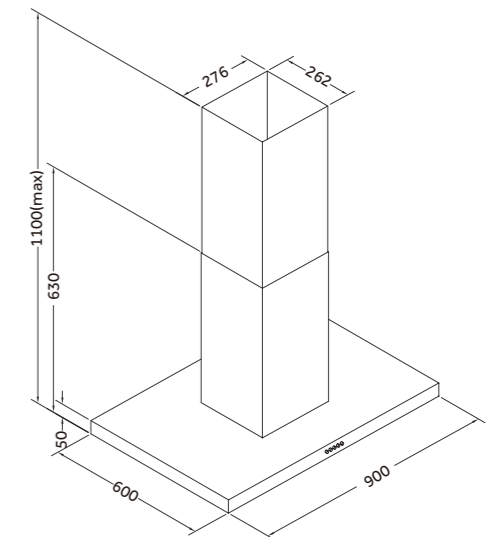

**VIS90A-BL160**

Technical specification	Technical information	Optional:
General input: 164W	Push button control	Halogen lights
Airflow: 750m³/h	3 speeds	
Noise level: ≤58dB	160W motor	
Net weight: 21.4kgs	4 x 1W LED lights	
Gross weight: 24.5kgs	90cm width	
Appliance dimension : 900×600×(630~1100)mm	Cassette metallic filter	
Packing dimension: 975×370×675mm		
Container loading(20' /40' /40' HQ pcs): 100/220/260		

## COOKER HOOD

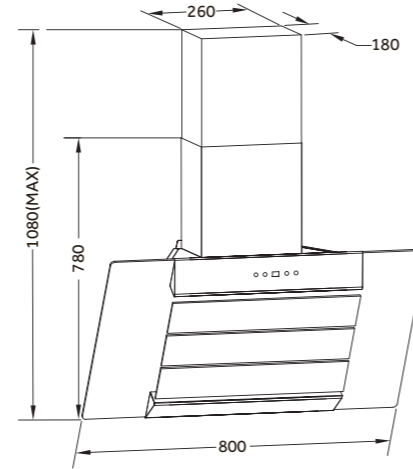

### VAH80E-L1T BK

Technical specification	Technical information	Optional:
General Input: 122W	Extraction or recirculation	Halogen lights
Airflow: 550m³/h	Electronic soft-touch control	60/70/90cm width
Noise Level: ≤58dB	3 speeds	Push button control
Net Weight: 15.0kgs	120W motor	
Gross Weight: 17.5kgs	2 x 1W LED lights	
Appliance Dimension: 800×340×780~1080mm	80cm width	
Packing Dimension: 860×390×500mm	Cassette metallic filter	
Container Loading(20' /40' /40' HQ pcs): 164/350/410		

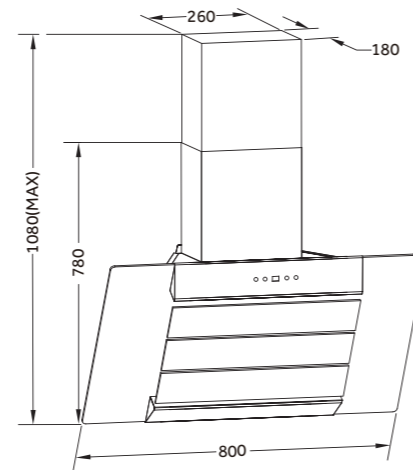

### VAH80E-L1T SS

Technical specification	Technical information	Optional:
General Input: 122W	Extraction or recirculation	Halogen lights
Airflow: 550m³/h	Electronic soft-touch control	60/70/90cm width
Noise Level: ≤58dB	3 speeds	Push button control
Net Weight: 15.0kgs	120W motor	
Gross Weight: 17.5kgs	2 x 1W LED lights	
Appliance Dimension: 800×340×780~1080mm	80cm width	
Packing Dimension: 860×390×500mm	Cassette metallic filter	
Container Loading(20' /40' /40' HQ pcs): 164/350/410		

## COOKER HOOD

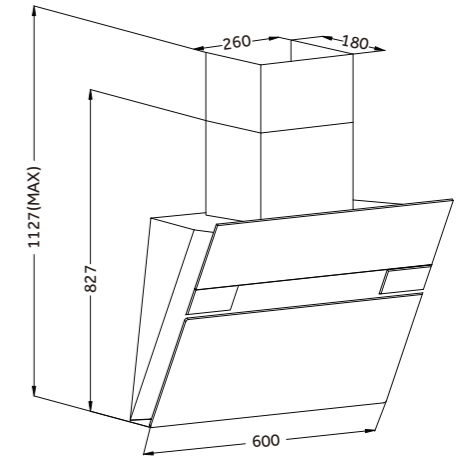

### VAH60E-L2

Technical specification	Technical information	Optional:
General Input: 122W	Touch sensor control	Push button control
Airflow: 550m³/h	3 speeds	90cm width
Noise Level: ≤58dB	120W motor	
Net Weight: 12.5kgs	2 x 1W LED lights	
Gross Weight: 15.0kgs	60cm width	
Appliance Dimension: 600x333x(827~1127)mm	Cassette metallic filter	
Packing Dimension: 660×455×500mm	Filter cover	
Container Loading(20' /40' /40' HQ pcs): 200/410/440		

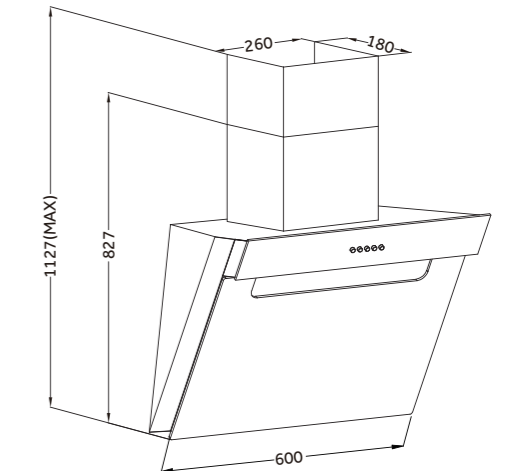

### VAH60A-L3

Technical specification	Technical information	Optional:
General Input: 122W	Push button control	Touch sensor control
Airflow: 550m³/h	3 speeds	90cm width
Noise Level: ≤58dB	120W motor	
Net Weight: 13.5kgs	2 x 1W LED lights	
Gross Weight: 16kgs	60cm width	
Appliance Dimension: 600x373x(827~1127)mm	Cassette metallic filter	
Packing Dimension: 660×455×500mm	Filter cover	
Container Loading(20' /40' /40' HQ pcs): 200/410/440		

## COOKER HOOD

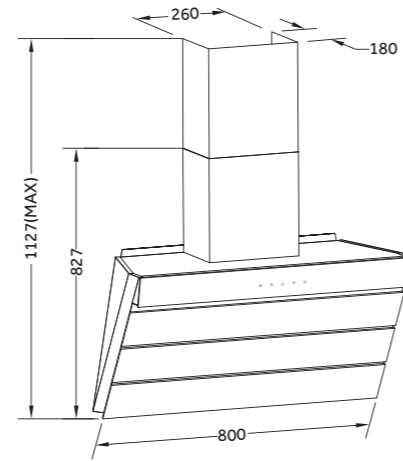

### VAH80E-L3T

Technical specification	Technical information	Optional:
General input: 122W	Touch sensor control	Push button control
Airflow: 550m³/h	3 speeds	Halogen lights
Noise level: ≤58dB	120W motor	60/70/90cm optional
Net weight: 15.0kgs	2 x 1W LED Lights	
Gross weight: 17.5kgs	80cm width	
Appliance dimension : 800×373×(827~1127)mm	Cassette metallic filter	
Packing dimension: 860×455×500mm	Filter cover	
Container loading(20' /40' /40' HQ pcs): 145/300/335		

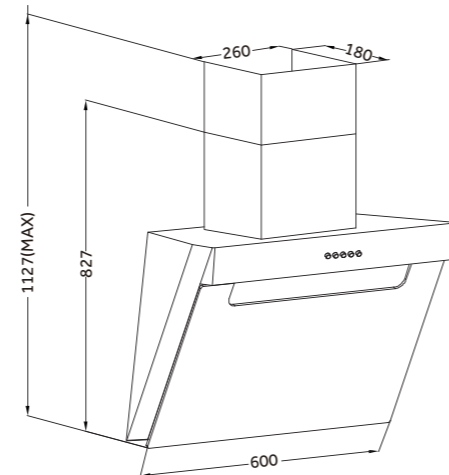

### VAH60A-L3 SS

Technical specification	Technical information	Optional:
General Input: 122W	Push button control	Touch sensor control
Airflow: 550m³/h	3 speeds	80cm width
Noise Level: ≤58dB	120W motor	
Net Weight: 13.0kgs	2 x 1W LED lights	
Gross Weight: 15.5kgs	60cm width	
Appliance Dimension : 600×333×(827~1127)mm	Cassette metallic filter	
Packing Dimension : 660×445×505mm	Filter cover	
Container Loading(20' /40' /40' HQ pcs) : 195/400/440		

## COOKER HOOD

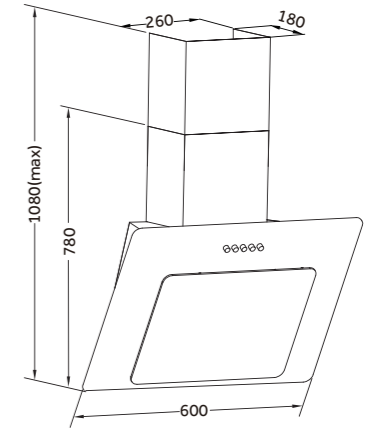

### VNB60A-L6A

Technical specification	Technical information	Optional:
General input: 162W	Push button control	Touch sensor control
Airflow: 650m³/h	3 speeds	70/80/90cm optional
Noise level: ≤58dB	160W motor	White
Net weight: 13.5kgs	2 x 1W LED Lights	
Gross weight: 15.0kgs	60cm width	
Appliance dimension: 600×313×(780~1080)mm	Cassette metallic filter	
Packing dimension: 660×360×520mm	Filter cover	
Container loading(20' /40' /40' HQ pcs): 225/471/550	Energy Class: A	

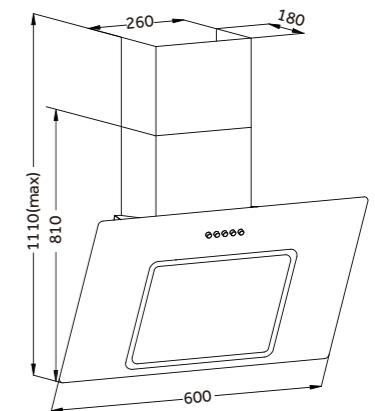

### VNB60A-L8A

Technical specification	Technical information	Optional:
General input: 162W	Push button control	Touch sensor control
Airflow: 650m³/h	3 speeds	70/80/90cm optional
Noise level: ≤58dB	160W motor	
Net weight: 14.0kgs	2 x 1W LED lamps	
Gross weight: 16.5kgs	60cm width	
Appliance dimension: 600×330×(810~1110)mm	Cassette metallic filter	
Packing dimension: 650×390×560mm	Filter cover	
Container loading(20' /40' /40' HQ pcs): 195/400/470	Energy Class: A	

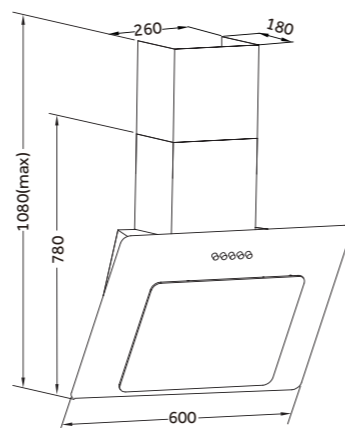

**VAH60A-L6B**

Technical specification	Technical information	Optional:
General input: 112W	Push button control	Touch sensor control
Airflow: 550m³/h	3 speeds	70/80/90cm optional
Noise level: ≤58dB	110W motor	White
Net weight: 12.0kgs	2 x 1W LED Lights	
Gross weight: 14.2kgs	60cm width	
Appliance dimension: 600×313×(780~1080)mm	Cassette metallic filter	
Packing dimension: 660×360×450mm	Filter cover	
Container loading(20' /40' /40' HQ pcs): 270/550/670	Energy Class: B	

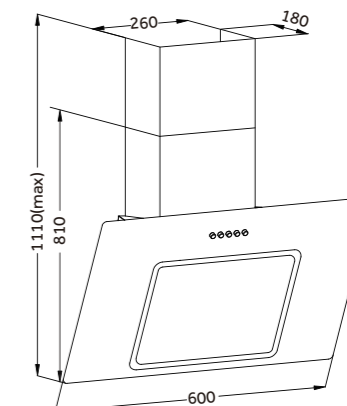

**VAH60A-L8**

Technical specification	Technical information	Optional:
General input: 122W	Push button control	Touch sensor control
Airflow: 550m³/h	3 speeds	28W halogen lamp
Noise level: ≤58dB	120W motor	70/80/90cm optional
Net weight: 12.2kgs	2 x 1W LED lamps	
Gross weight: 14.6kgs	60cm width	
Appliance dimension: 600×330×(810~1110)mm	Cassette metallic filter	
Packing dimension: 650×390×490mm	Filter cover	
Container loading(20' /40' /40' HQ pcs): 220/460/556		

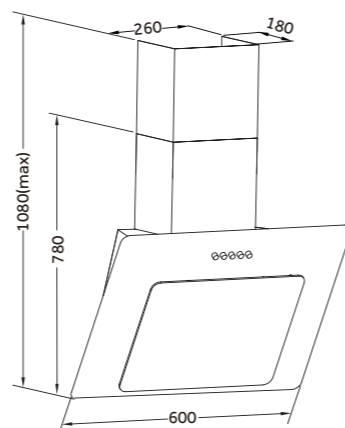

**VAH60A-H6A**

Technical specification	Technical information	Optional:
General input: 176W	Push button control	Touch sensor control
Airflow: 550m³/h	3 speeds	LED lights
Noise level: ≤58dB	120W motor	70/80/90cm optional
Net weight: 12.2kgs	2 x 28W halogen lights	
Gross weight: 14.4kgs	60cm width	
Appliance dimension: 600×313×(780~1080)mm	Cassette metallic filter	
Packing dimension: 660×360×450mm	Filter cover	
Container loading(20' /40' /40' HQ pcs): 270/550/670		

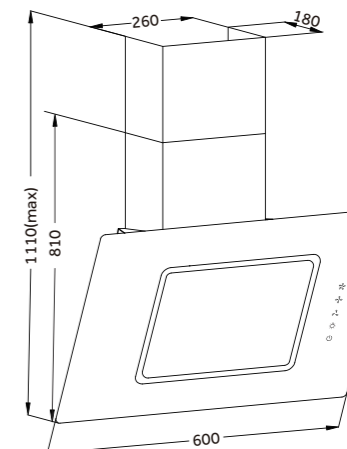

**VAH60EC-L8**

Technical specification	Technical information	Optional:
General input: 122W	Touch sensor control	Push button control
Airflow: 550m³/h	3 speeds	Halogen lights
Noise level: ≤58dB	120W motor	70/80/90cm optional
Net weight: 12.2kgs	2 x 1W LED Lights	
Gross weight: 14.6kgs	60cm width	
Appliance dimension: 600×330×(810~1110)mm	Cassette metallic filter	
Packing dimension: 650×390×490mm	Filter cover	
Container loading(20' /40' /40' HQ pcs): 220/460/556		

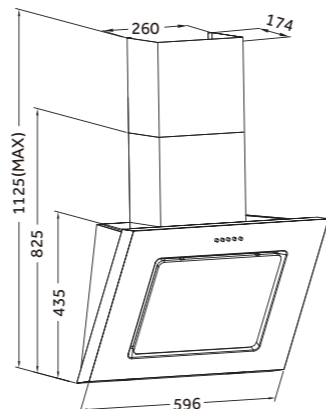

**VAH60A-H9**

Technical specification	Technical information	Optional:
General input: 176W	Push button control	Touch sensor control
Airflow: 550m³/h	3 speeds	LED lights
Noise level: ≤58dB	120W motor	
Net weight: 9.4kgs	2 x 28W halogen lights	
Gross weight: 11.8kgs	60cm width	
Appliance dimension : 600×331×(825~1125)mm	Cassette metallic filter	
Packing dimension: 650×385×500mm	Filter cover	
Container loading(20' /40' /40' HQ pcs): 224/464/576		

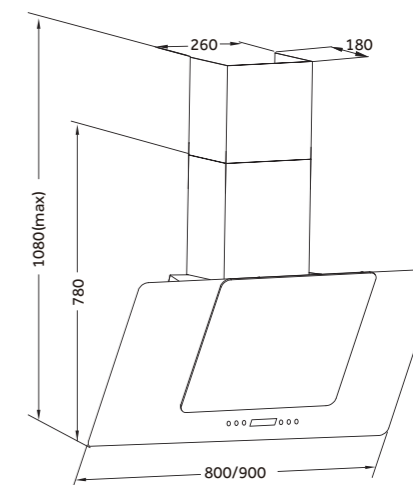

**VAH80E-H6D**

Technical specification	Technical information	Optional:
General input: 176W	Touch sensor control	Push button control
Airflow: 550m³/h	3 speeds	LED Lights
Noise level: ≤58dB	120W motor	60/70/80/90cm optional
Net weight: 19.0kgs	2 x 28W halogen lights	
Gross weight: 22.0kgs	80cm width	
Appliance dimension : 800×345×(780~1080)mm	Cassette metallic filter	
Packing dimension: 860×365×450mm	Filter cover	
Container loading(20' /40' /40' HQ pcs): 190/410/480		

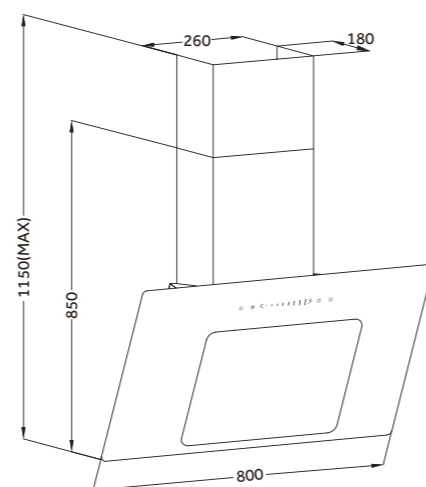

**VAH80ES-H7**

Technical specification	Technical information	Optional:
General input: 216W	Touch sensor control	Push button control
Airflow: 750m³/h	4 speeds	LED Lights
Noise level: ≤58dB	160W motor	60/70/80/90cm optional
Net weight: 14.5kgs	2 x 28W halogen lights	
Gross weight: 17.0kgs	80cm width	
Appliance dimension : 800×375×(850~1150)mm	Cassette metallic filter	
Packing dimension: 860×445×530mm	Filter cover	
Container loading(20' /40' /40' HQ pcs): 130/280/330		

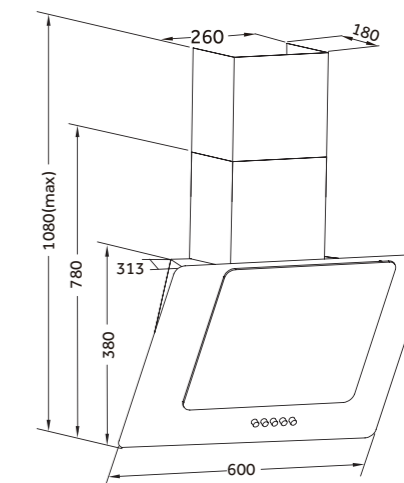

**VAH60A-L6K**

Technical specification	Technical information	Optional:
General input: 122W	Push button control	Touch sensor control
Airflow: 550m³/h	3 speeds	2 x 28W Halogen lights
Noise level: ≤58dB	120W motor	70/80/90cm optional
Net weight: 12.6kgs	2 x 1W LED lights	
Gross weight: 14.7kgs	60cm width	
Appliance dimension : 600×313×(780~1080)mm	Cassette metallic filter	
Packing dimension: 660×375×465mm	Filter cover	
Container loading(20' /40' /40' HQ pcs): 240/490/580		

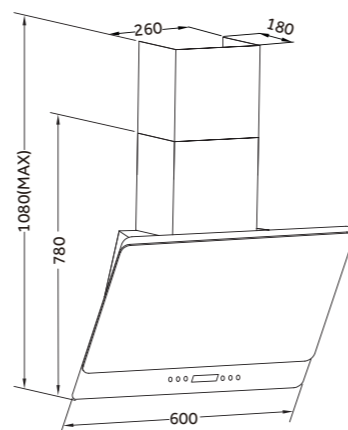

**VAH60E-H10D**

Technical specification	Technical information	Optional:
General input: 176W	Touch sensor control	Push button control
Airflow: 550m³/h	3 speeds	LED Lights
Noise level: ≤58dB	120W motor	60/70/80/90cm optional
Net weight: 12.4kgs	2 x 28W halogen lights	
Gross weight: 14.6kgs	80cm width	
Appliance dimension : 600×313×(780~1080)mm	Cassette metallic filter	
Packing dimension: 660×360×450mm	Filter cover	
Container loading(20' /40' /40' HQ pcs): 270/550/670		

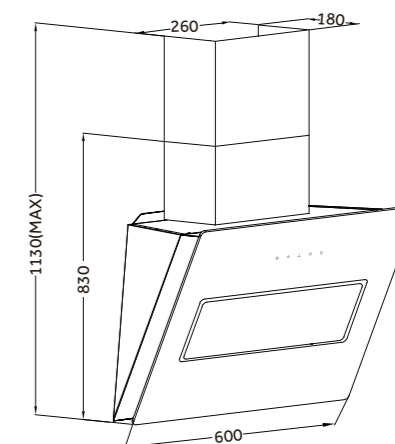

**VAH60E-L5**

Technical specification	Technical information	Optional:
General input: 122W	Touch sensor control	Push button control
Airflow: 550m³/h	3 speeds	Halogen lights
Noise level: ≤58dB	120W motor	80cm optional
Net weight: 14.0kgs	2 x 1W LED Lights	
Gross weight: 16.0kgs	60cm width	
Appliance dimension : 600×351×(830~1130)mm	Cassette metallic filter	
Packing dimension: 660×455×500mm	Filter cover	
Container loading(20' /40' /40' HQ pcs): 205/418/450		

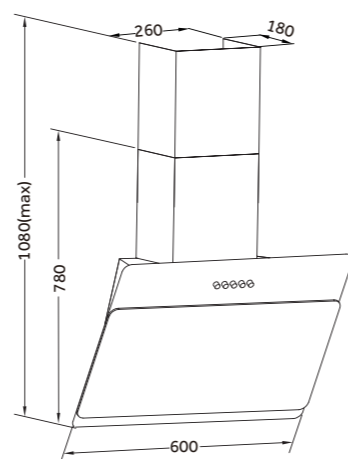

**VAH60A-H10**

Technical specification	Technical information	Optional:
General input: 176W	Push button control	Touch sensor control
Airflow: 550m³/h	3 speeds	LED lights
Noise level: ≤58dB	120W motor	70/80/90cm optional
Net weight: 12.4kgs	2 x 28W halogen lights	
Gross weight: 14.6kgs	60cm width	
Appliance dimension : 600×313×(780~1080)mm	Cassette metallic filter	
Packing dimension: 660×360×450mm	Filter cover	
Container loading(20' /40' /40' HQ pcs): 270/550/670		

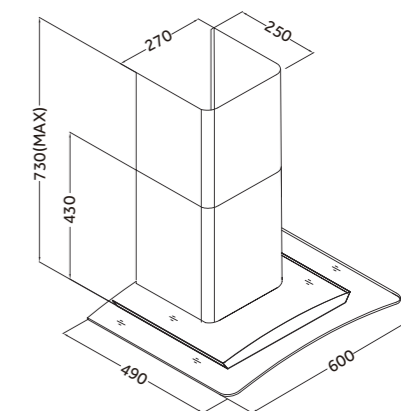

**VQD60E-G6L120L3**

Technical specification	Technical information	Technical information
General Input: 125W	Extraction or recirculation	Red / Green / Blue
Airflow: 550m³/h	Touch sensor control	
Noise Level: ≤58dB	3 speeds	<b>Optional:</b>
Net Weight: 11.6kgs	120W motor	Push button control
Gross Weight: 13.4kgs	2 x 1W LED lights	90cm width
Appliance Dimension : 600×490×230mm	60cm width	
Packing Dimension : 650×350×540mm	Cassette metallic filter	
Container Loading(20' /40' /40' HQ pcs) : 220/460/540	3 Colors LED Edge lighting	



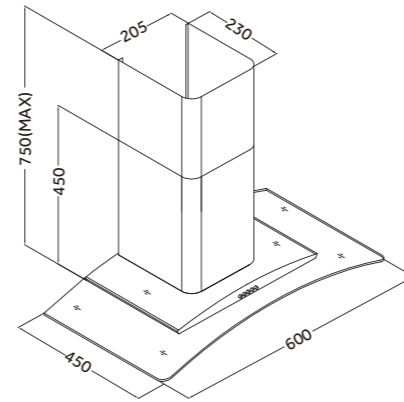

**VQD60A-CB1B**

Technical specification	Technical information	Optional:
General Input: 26W	Extraction or recirculation	90cm width
Airflow: 400m³/h	Push button control	2x1W LED lights
Noise Level: ≤52dB	3 speeds	
Net Weight: 10.1kgs	25W motor	
Gross Weight: 12.2kgs	1 x 1W LED light	
Appliance Dimension: 600x450x(450~770)mm	60cm width	
Packing Dimension: 650x510x250mm	Cassette metallic filter	
Container Loading(20`/40`/40`HQ pcs): 340/740/830	Energy Class: B	

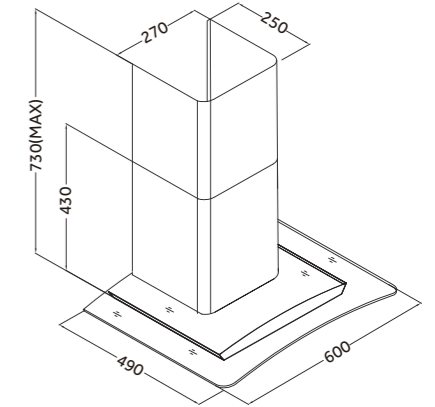

**VQD60E-G6L120**

Technical specification	Technical information	Optional:
General Input: 122W	Extraction or recirculation	Push button control
Airflow: 550m³/h	Touch sensor control	90cm width
Noise Level: ≤58dB	3 speeds	
Net Weight: 11.6kgs	120W motor	
Gross Weight: 13.4kgs	2 x 1W LED lights	
Appliance Dimension: 600x490x230mm	60cm width	
Packing Dimension: 650x290x530mm	Cassette metallic filter	
Container Loading(20`/40`/40`HQ pcs): 290/580/720		

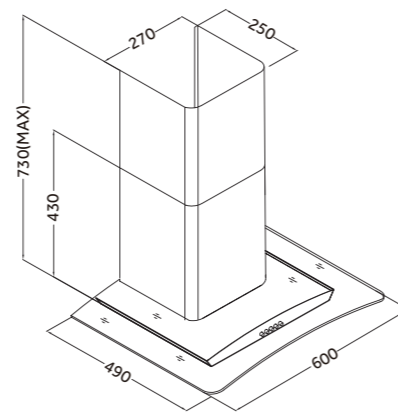

**VQD60A-G6N120**

Technical specification	Technical information	Optional:
General Input: 200W	Extraction or recirculation	Electronic soft-touch control
Airflow: 550m³/h	Push button control	90cm width
Noise Level: ≤58dB	3 speeds	LED lights
Net Weight: 11.0kgs	120W motor	
Gross Weight: 12.5kgs	2 x 40W incandescent lights	
Appliance Dimension: 600x490x230mm	60cm width	
Packing Dimension: 650x290x530mm	Cassette metallic filter	
Container Loading(20`/40`/40`HQ pcs): 290/580/720		

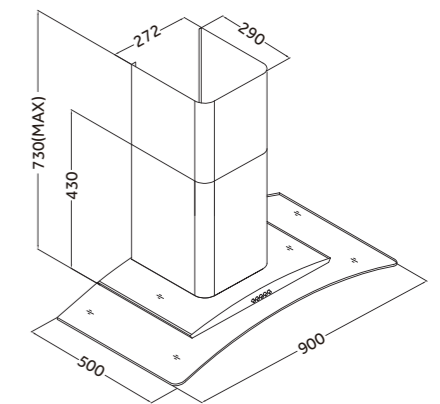

**VQD90A-G6L160T**

Technical specification	Technical information	Optional:
General Input: 162W	Extraction or recirculation	Electronic soft-touch control
Airflow: 750m³/h	Push button control	
Noise Level: ≤58dB	3 speeds	
Net Weight: 15kgs	160W motor	
Gross Weight: 17.5kgs	2 x 1W LED lights	
Appliance Dimension: 900x500x330mm	90cm width	
Packing Dimension: 950x360x600mm	Cassette metallic filter	
Container Loading(20`/40`/40`HQ pcs): 130/275/320		

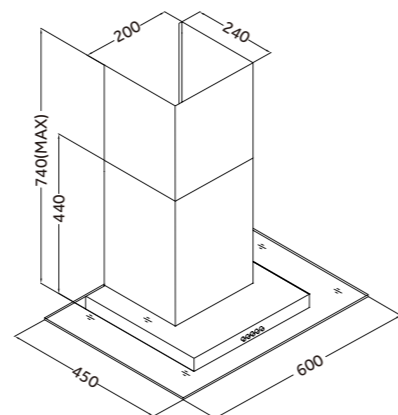

**VCH60A-TB1B**

Technical specification	Technical information	Optional:
General Input: 26W	Extraction or recirculation	2x1W LED lights
Airflow: 400m³/h	Push button control	60/70/80/90cm width
Noise Level: ≤52dB	3 speeds	
Net Weight: 8.0kgs	25W motor	
Gross Weight: 10.0kgs	1 x 1W LED light	
Appliance Dimension: 600x450x(440~740)mm	60cm width	
Packing Dimension: 650x510x250mm	Cassette metallic filter	
Container Loading(20' /40' /40' HQ pcs): 340/740/830	Energy Class: B	

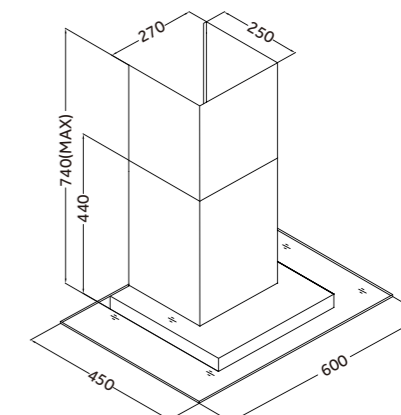

**VCH60E-TB2**

Technical specification	Technical information	Optional:
General Input: 122W	Extraction or recirculation	Push button control
Airflow: 550m³/h	Touch sensor control	90cm width
Noise Level: ≤58db	3 speeds	Halogen lights
Net Weight: 11.6kgs	120W motor	
Gross Weight: 13.8kgs	2 x 1W LED lights	
Appliance Dimension: 600x450x(440~740)mm	60cm width	
Packing Dimension: 650x510x290mm	Cassette metallic filter	
Container Loading(20' /40' /40' HQ pcs): 310/620/720		

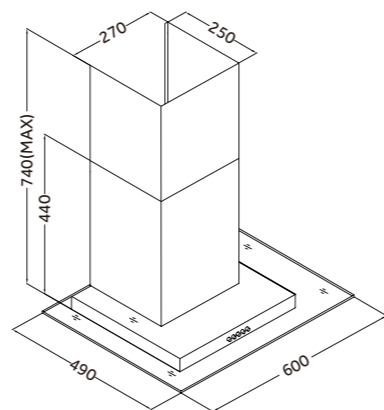

**VCH60A-G1N120**

Technical specification	Technical information	Optional:
General Input: 200W	Extraction or recirculation	Electronic soft-touch control
Airflow: 550m³/h	Push button control	90cm width
Noise Level: ≤58db	3 speeds	LED lights
Net Weight: 10.7kgs	120W motor	
Gross Weight: 12.4kgs	2 x 40W incandescent lights	
Appliance Dimension: 600x490x230mm	60cm width	
Packing Dimension: 650x290x530mm	Cassette metallic filter	
Container Loading(20' /40' /40' HQ pcs): 290/588/720		

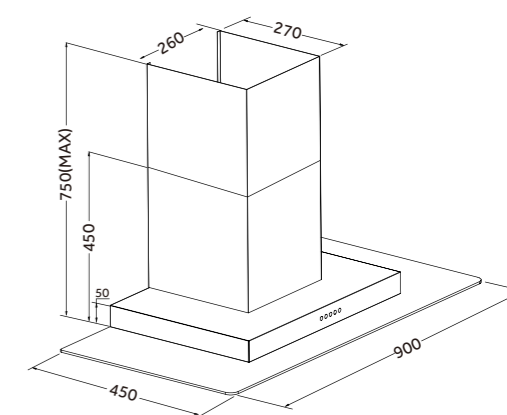

**VCH90A-TB3**

Technical specification	Technical information	Optional:
General Input: 161W	Extraction or recirculation	60/70/80cm width
Airflow: 750m³/h	Push button control	
Noise Level: ≤58dB	3 speeds	
Net Weight: 15.0kgs	160W motor	
Gross Weight: 17.5kgs	1 x 1W LED light	
Appliance Dimension: 900x450x(450~750)mm	90cm width	
Packing Dimension: 960x510x420mm	Cassette metallic filter	
Container Loading(20' /40' /40' HQ pcs): 140/300/340		

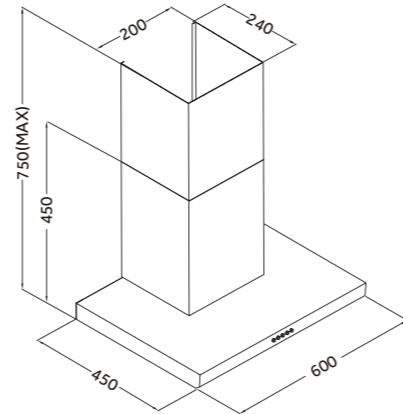

**VCH60A-T1B**

Technical specification	Technical information	Optional:
General Input: 26W	Extraction or recirculation	90cm width
Airflow: 400m³/h	Push button control	2x1W LED lights
Noise Level: ≤52dB	3 speeds	
Net Weight: 6.5kgs	25W motor	
Gross Weight: 8.5kgs	1 x 1W LED light	
Appliance Dimension: 600x450x(450~750)mm	60cm width	
Packing Dimension: 650x510x250mm	Cassette metallic filter	
Container Loading(20`/40`/40` HQ pcs): 340/740/830	Energy Class: B	

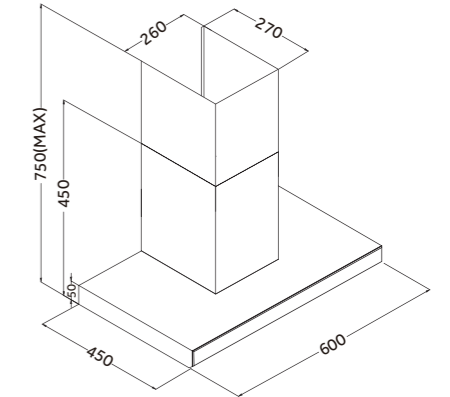

**VCH60E-T2L120**

Technical specification	Technical information	Optional:
General input: 122W	Extraction or recirculation	Push button control
Airflow: 550m³/h	Touch sensor control	90cm width
Noise level: ≤58dB	3 fan speeds	
Net weight: 9.2kgs	120W motor	
Gross weight: 11.0kgs	2 x 1W LED lights	
Appliance dimension: 600x450x(450~750)mm	60cm width	
Packing dimension: 650x325x535mm	Cassette metallic filter	
Container loading(20`/40`/40` HQ pcs): 250/500/630		

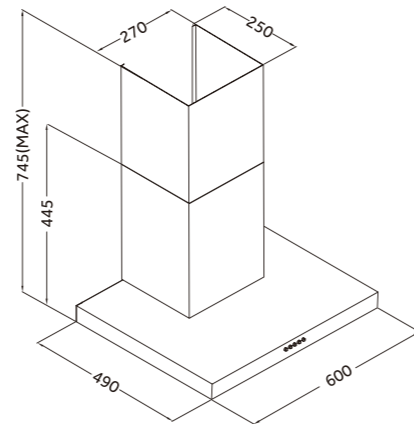

**VCH60A-N120**

Technical specification	Technical information	Optional:
General Input: 200W	Extraction or recirculation	Electronic soft-touch control
Airflow: 550m³/h	Push button control	90cm width
Noise Level: ≤58dB	3 speeds	LED lights
Net Weight: 10.5kgs	120W motor	
Gross Weight: 12.5kgs	2x40W incandescent lights	
Appliance Dimension: 600x490x230mm	60cm width	
Packing Dimension: 650x290x530mm	Cassette metallic filter	
Container Loading(20`/40`/40` HQ pcs): 290/588/720		

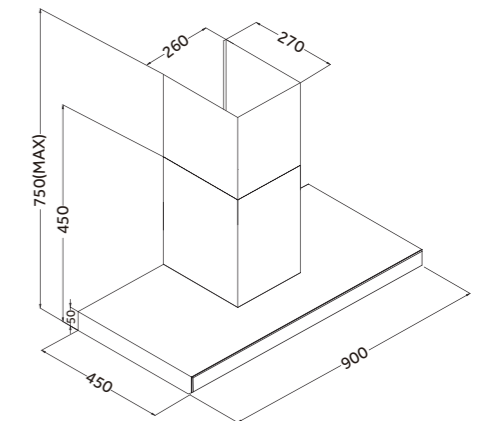

**VCH90E-T3L160**

Technical specification	Technical information	Optional:
General input: 162W	Extraction or recirculation	Push button control
Airflow: 750m³/h	Touch sensor control	60cm width
Noise level: ≤58dB	3 fan speeds	
Net weight: 14.4kgs	160W motor	
Gross weight: 16.6kgs	2 x 1W LED lights	
Appliance dimension: 900x450x(450~750)mm	90cm width	
Packing dimension: 960x405x515mm	Cassette metallic filter	
Container loading(20`/40`/40` HQ pcs): 135/280/350		

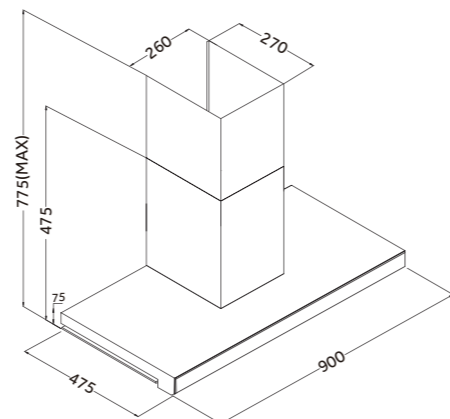

### VCH90E-T4

Technical specification	Technical information	Optional:
General Input: 162W	Extraction or recirculation	Halogen lights
Airflow: 750m <sup>3</sup> /h	Touch sensor control	SS Filter cover
Noise Level: ≤58dB	3 speeds	
Net Weight: 15.0kgs	160W motor	
Gross Weight: 17.5kgs	2 x 1W LED lights	
Appliance Dimension: 900×475×(475~775)mm	90cm width	
Packing Dimension: 960×535×480mm	Cassette metallic filter	
Container Loading(20' /40' /40' HQ pcs): 113/230/270		

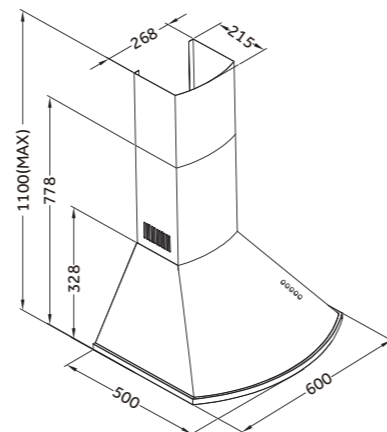

### VRH60A-H

Technical specification	Technical information	Optional:
General Input: 240W	Extraction or recirculation	Electronic soft-touch control
Airflow: 750m <sup>3</sup> /h	Push button control	
Noise Level: ≤58dB	3 speeds	
Net Weight: 10.0kgs	160W motor	
Gross Weight: 11.7kgs	2 x 40W halogen lights	
Appliance Dimension: 600×500×330mm	60cm width	
Packing Dimension: 650×570×400mm	Cassette metallic filter	
Container Loading(20' /40' /40' HQ pcs): 180/380/520		

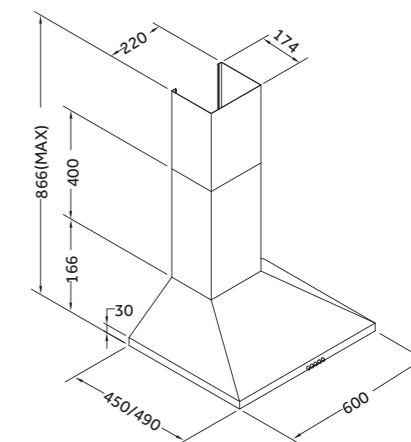

### VKH60A-F2N120-E

Technical specification	Technical information	Optional:
General input: 200W	Extraction or recirculation	350m <sup>3</sup> /h airflow
Airflow: 550m <sup>3</sup> /h	Push button control	Halogen lights
Noise level: ≤55dB	3 speeds	Depth 49cm
Net weight: 6.5kgs	120W motor	
Gross weight: 7.8kgs	2 x 40W incandescent lights	
Appliance dimension: 600×450×(566~866)mm	60cm width	
Packing dimension: 650×230×490mm	Cassette metallic filter	
Container loading(20' /40' /40' HQ pcs): 400/800/900		

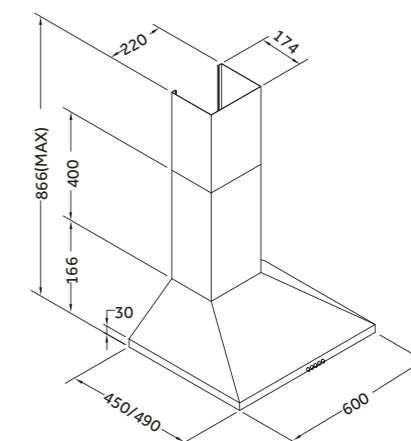

### VKH60A-F3LB

Technical specification	Technical information	Optional:
General input: 26W	Extraction or recirculation	350m <sup>3</sup> /h airflow
Airflow: 400m <sup>3</sup> /h	Push button control	Halogen lights
Noise level: ≤55dB	3 speeds	Depth 49cm
Net weight: 6.5kgs	25W motor	
Gross weight: 7.8kgs	1 x 1W LED light	
Appliance dimension: 600×450×(566~866)mm	60cm width	
Packing dimension: 650×230×490mm	Cassette metallic filter	
Container loading(20' /40' /40' HQ pcs): 400/800/900	Energy Class B	

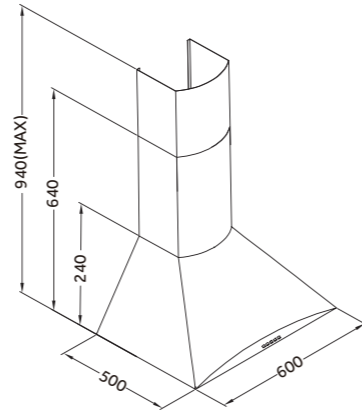

**VRC60A**

Technical specification	Technical information	Optional:
General Input: 240W	Extraction or recirculation	LED lights
Airflow: 750m³/h	Push button control	
Noise Level: ≤58dB	3 speeds	
Net Weight: 8.1kgs	160W motor	
Gross Weight: 10.1kgs	2 x 40W halogen lights	
Appliance Dimension: 600×500×240mm	60cm width	
Packing Dimension: 650×335×545mm	Cassette metallic filter	
Container Loading(20`/40`/40`HQ pcs): 260/530/600		

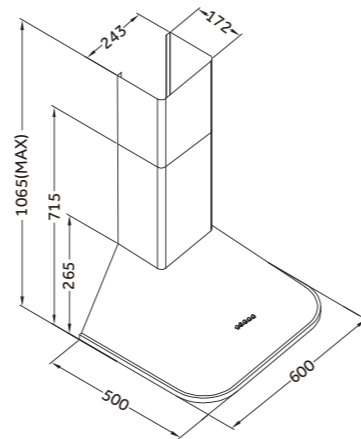

**VRH60A**

Technical specification	Technical information	Optional:
General Input: 180W	Extraction or recirculation	Electronic soft-touch control
Airflow: 650m³/h	Push button control	2 x 28W halogen lights
Noise Level: ≤58dB	3 speeds	
Net Weight: 10.8kgs	100W motor	
Gross Weight: 12.6kgs	2 x 40W incandescent lights	
Appliance Dimension: 600×500×290mm	60cm width	
Packing Dimension: 660×350×570mm	Cassette metallic filter	
Container Loading(20`/40`/40`HQ pcs): 220/465/525		

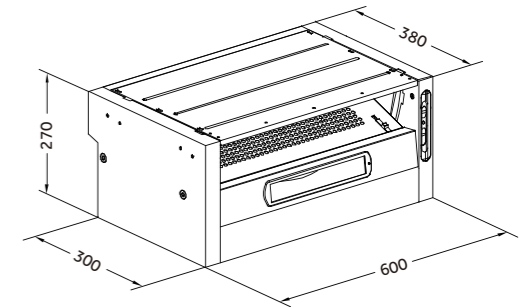

**VBHK10**

Technical specification	Technical information	Optional:
General Input: 160W	Extraction or recirculation	2 motors
Airflow: 275m³/h	Slider control	Cassette metallic filter
Noise Level: ≤54dB	3 speeds	2×40W lights
Net Weight: 8.5kgs	120W motor	
Gross Weight: 10.3kgs	1 x 40W incandescent light	
Appliance Dimension: 600×380×270mm	60cm width	
Packing Dimension: 660×330×450mm	Acrylic filter	
Container Loading(20`/40`/40`HQ pcs): 320/670/750		

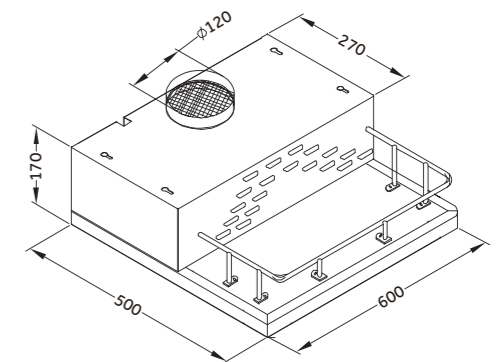

**VST10A(F)**

Technical specification	Technical information	Optional:
General Input: 160W	Extraction or recirculation	Slider control
Airflow: 275m³/h	Push button control	
Noise Level: ≤54dB	3 speeds	
Net Weight: 7.1kgs	120W motor	
Gross Weight: 8.3kgs	1 x 40W incandescent light	
Appliance Dimension: 600×500×170mm	60cm width	
Packing Dimension: 657×230×562mm	Cassette metallic filter	
Container Loading(20`/40`/40`HQ pcs): 370/750/850		

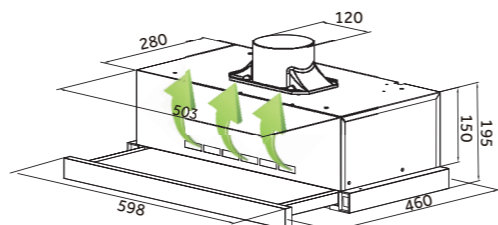

**VTH60F**

Technical specification	Technical information	Optional:
General input: 150 W	Extraction or recirculation	2x28W halogen lights
Airflow: 400m³/h	Rocker switch	2X1W LED lights
Noise level: ≤54dB	2 speeds	76cm width
Net weight: 7.0kgs	70W motor	
Gross weight: 8.2kgs	2 x 40W incandescent lights	
Appliance dimension : 598x(300~460)x195mm	60cm width	
Packing dimension: 680x385x260mm	Cassette metallic filter	
Container loading(20`/40`/40`HQ pcs): 450/930/1050	2 fans	

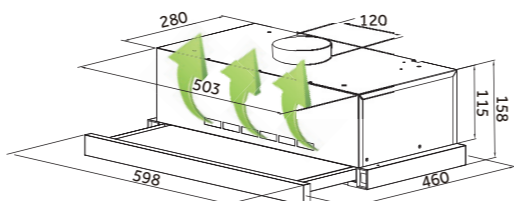

**VTH60L**

Technical specification	Technical information	Optional:
General input: 120W	Extraction or recirculation	2X1W LED lights
Airflow: 275m³/h	Rocker switch	1x28W halogen light
Noise level: ≤52dB	2 speeds	
Net weight: 5.5kgs	80W motor	
Gross weight: 6.5kgs	1x40W incandescent light	
Appliance dimension : 598x(300~460)x158mm	60cm width	
Packing dimension: 662x378x225mm	Cassette metallic filter	
Container loading(20`/40`/40`HQ pcs): 450/930/1230		

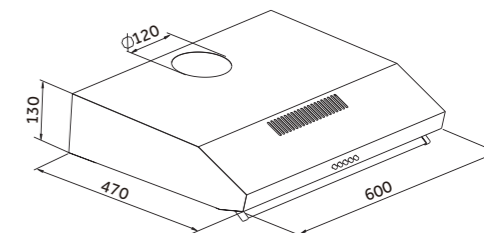

**VDH10A**

Technical specification	Technical information	Optional:
General input: 140W	Extraction or recirculation	2x80W motors
Airflow: 275m³/h	Rocker switch	Acrylic filter
Noise level: ≤52dB	3 speeds	50/60/70/80/90cm optional
Net weight: 5.0kgs	1x60W motor	
Gross weight: 5.8kgs	2x40W incandescent light	
Appliance dimension : 600x470x130mm	60cm width	
Packing dimension: 630x510x165mm	Cassette metallic filter	
Container loading(20`/40`/40`HQ pcs): 550/1140/1330		

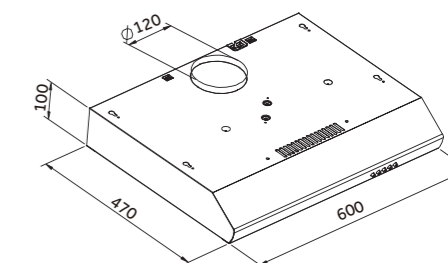

**VTC60A**

Technical specification	Technical information	Optional:
General input: 105W	Electronic soft-touch control	50/75cm width
Airflow: 255m³/h	Push button control	Cassette metallic filter
Noise level: ≤52dB	3 speeds	
Net weight: 4.5kgs	80W motor	
Gross weight: 5.2kgs	1 x 25W incandescent light	
Appliance dimension : 600x470x100mm	60cm width	
Packing dimension: 630x130x500mm	Acrylic filter	
Container loading(20`/40`/40`HQ pcs): 750/1530/1680		

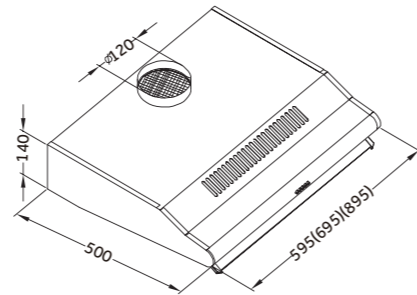

**VWH10A-D**

Technical specification	Technical information	Optional:
General Input: 140W	Extraction or recirculation	2x70W motors
Airflow: 275m³/h	Push button control	50/60/70/80/90cm optional
Noise Level: ≤54dB	3 speeds	Acrylic filter
Net Weight: 5.4kgs	60W motor	
Gross Weight: 6.2kgs	2 x 40W incandescent lights	
Appliance Dimension: 600×500×140mm	60cm width	
Packing Dimension: 630×175×530mm	Cassette metallic filter	
Container Loading(20' /40' /40' HQ pcs): 515/1060/1200		

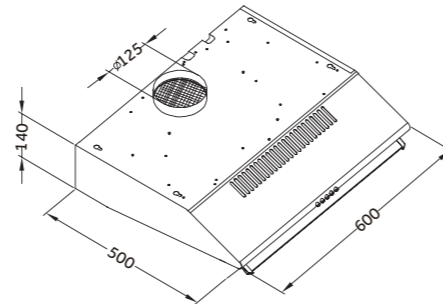

**VMH10A-D**

Technical specification	Technical information	Optional:
General Input: 140W	Extraction or recirculation	2x70W motors
Airflow: 275m³/h	Push button control	50/60/70/80/90cm optional
Noise Level: ≤54dB	3 speeds	Acrylic filter
Net Weight: 5.4kgs	60W motor	
Gross Weight: 6.2kgs	2 x 40W incandescent lights	
Appliance Dimension: 600×500×140mm	60cm width	
Packing Dimension: 630×175×530mm	Cassette metallic filter	
Container Loading(20' /40' /40' HQ pcs): 515/1060/1200		

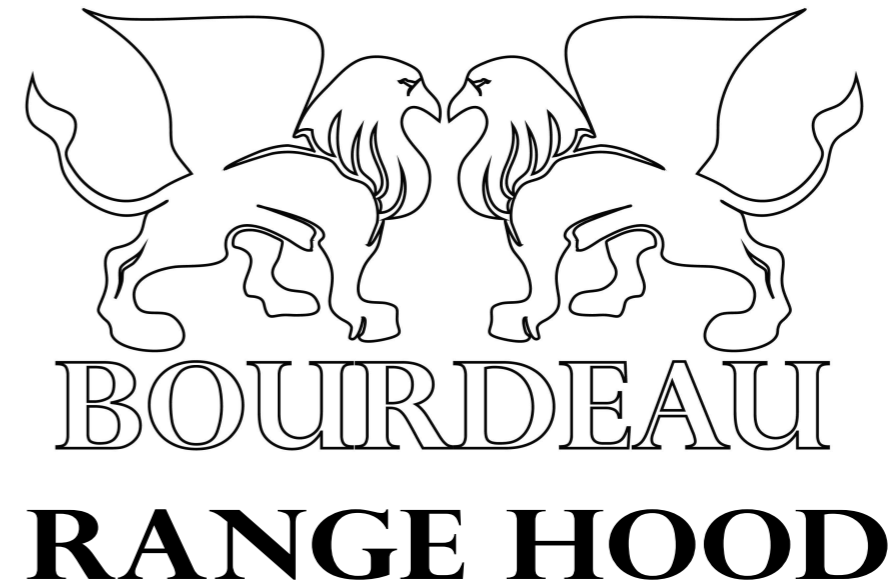

[www.BorudeauGriffin.com](http://www.BorudeauGriffin.com)  
 8233-37 S Princeton Ave. Chicago, IL 60620

Contact: Frantzie Bourdeau-Griffin

312-379-0940

[frantzie@BourdeauGriffin.com](mailto:frantzie@BourdeauGriffin.com)